



142-DR500

Portable edgebander for ABS

Operating instructions



Distributor:

IGM nástroje a stroje s.r.o.
Ke Kopanině 560, 252 67, Tuchoměřice
Czech Republic, EU
Phone: +420 220 950 910
E-mail: sales@igmttools.com
Website: www.igmttools.com

2022-07-12

142-DR500 IGM Portable Edgebander for ABS Manual EN v2.2.00 A4ob



Operating instructions EN

Please read this manual thoroughly and follow the safety instructions in it! Technical changes and printing errors reserved!

Dear customer,

This manual contains important instructions and information for the installation and proper use of the edgebander DR500.

This manual is part of the machine and therefore it should not be kept elsewhere than in the vicinity of the machine so that you can be consulted at any time by you or other persons operating the machine.



Please read and follow the safety instructions!

Carefully read these instructions before using the machine. Operation of the machine will be simpler and you will also lower the risk of injury while eliminating the probability of incorrect operation and possible damage to the machine.

Because of our policy of constant improvement, the design, construction or pictures may differ slightly. Should you discover any mistakes, please contact us at podpora@igm.cz.

TABLE OF CONTENTS	PAGE		
1. DECLARATION OF CONFORMITY	2	6.1.3 Adjusting the amount of glue	7
2. WARRANTY SERVICE	3	6.1.4 Adjusting tape thickness	7
3. SAFETY INSTRUCTIONS	3	6.1.5 Setting length of tape	7
3.1 Advice	3	6.1.6 Fastening the workpiece before edgebanding	7
3.2 General safety instructions	3	6.1.7 Refilling glue	7
3.3 Risks	3	6.2 Before turning on	7
3.4 Important notice	3	6.3 Functions of control panel	8
4. SPECIFICATIONS OF THE MACHINE	4	7. WORKING WITH THE EDGEBANDER	8
4.1 Machine description	4	7.1 Edgebanding	8
4.2 Technical data	4	7.2 Stationary use	9
4.3 Contents	4	7.2.1 Operation in battery mode	9
5. TRANSPORT, UNPACKING AND ASSEMBLY	4	7.3 Stationary use	9
5.1 Transport and unpacking	4	8. MAINTENANCE AND CONTROL	9
5.2 Assembly	5	8.1 Maintenance after work	9
5.2.1 Connecting the battery for portable operations	5	8.2 Preventive check	9
5.2.2 Mounting the mobile tape holder	5	9. MALFUNCTION ASSISTANCE	10
5.2.3 Mounting the corner guide	5	9.1 DR500 error messages	10
6. SET-UP AND ADJUSTMENT	6	9.2 Problem solving	10
6.1 Preparing for work	6	10. ENVIRONMENTAL PROTECTION	10
6.1.1 How to measure and set up the width of the tape	6	11. ACCESSORIES (SPARE PARTS)	10
6.1.2 Control and gauge set up on the supporting table	6		

1. DECLARATION OF CONFORMITY

The undersigned: IGM nástroje a stroje s.r.o.

Address: Ke Kopanině 560

Tuchoměřice, Praha-západ, PSČ 252 67

Czech Republic, EU

Phone no.: +420 220 950 910

Certifies the

Product: Manual Edgebander for ABS

Type: **DR500**

Manufacturer: CO-MATIC Machinery Co., Ltd., No. 473-16, San Feng Road, Houli District, Taichung City, Taiwan, R.O.C. 42156

We declare under our sole responsibility that the product described in this manual is in conformity with the following standards: EN ISO 12100, EN ISO 13857, EN 349, EN 953, EN 60204-1, EN ISO 11202, EN 55014-1, EN 55014-2 with the provisions of Directives 2006/42 / EC, 2004/108 / EC, 2006/95 / EC, 2002/95 / EC

Signed: Ivo Mlej
Managing Director



2. WARRANTY SERVICE

The warranty is subject to Terms and Conditions and Warranty Conditions of IGM nástroje a stroje s.r.o., the current version of which are available at www.igmtools.com.

3. SAFETY INSTRUCTIONS

3.1 Notice

This machine is designed for work with wood and wooden materials.

Proper use also includes compliance with the regular operational and maintenance work described in this manual.

The machine can be operated only by persons familiar with the operation procedures, maintenance and are aware of potential risks.

Comply with the minimum age limits specified by law. The machine may only be used when in perfect technical condition.

All safety and protective components must be installed when operating the machine.

Besides these instructions, also adhere to the safety instructions of your country and to the generally recognized technical practices concerning the operation of woodworking machinery.

The manufacturer or the supplier is not responsible for any damage resulting from improper use. Every user is responsible for their own actions.

Warranty cannot be claimed if any of the following principles are broken:

- Unsuitable work environment: high humidity, contamination.
- Damage caused by an improper assembly and/or improper storage.
- Use of damaged machinery.
- Failure to follow the operating instructions: transport, storage, assembly, putting into operation, cleaning and maintenance of the machine.
- Use of unauthorized spare parts.
- Unauthorized assembly of the machine.
- Do not use worn out spare parts.

3.2 General safety instructions

The machine can pose danger when improperly operated.

Thoroughly read the operating instructions and make sure that you understand everything before doing anything with the machine.

Keep this user manual clean and protect it from dirt and moisture; in case of re-selling, pass the manual onto the new owner.

Any alterations or changes to the machine are prohibited. Daily try out if the machine runs smoothly and check the function of protective covers before operating the machine. Remove any malfunctions or deficiencies found on the machine as well as

damaged protective cover. The machine may only be used when in perfect technical condition.

Use a hairnet or a hat to protect long hair. Wear tight-fitting clothes, remove all bracelets, rings, necklaces or ties. Wear work shoes only. In any case, do not wear casual shoes or sandals during work. Abide by the regulations for personal protection.

Always wear safety eyewear. Always use hearing protection.

Abide by the „safety“ instructions in this manual. Make sure you have enough space for your work.

Do not perform any operations that are not suitable for this machine.

Make sure you have good lighting.

Make sure the power cord is not in your way when working. Keep your work area clean. Never touch the machine when it's running.

Make sure you are concentrating and paying attention. Use caution. Never work under the influence of drugs and/or alcohol.

Make sure there are no children around when working with the machine. Never leave the machine unattended. Always switch the machine off when leaving the workspace.

Do not place anything on the machine.

The repair of electrical components can be only carried out by a professional. Damaged electric cord must be replaced immediately.

Before banding, remove nails and any other foreign objects that could be in the way of your work.

The switch must be in the „OFF“ position before you connect the machine to the power supply.

Do not use the machine if the ON-OFF switch does not work correctly.

The use of any other accessories than recommended by this manual be hazardous.

When the power cord is connected, temperature shows up on the digital display but heating does NOT begin.

Make sure the cable is long enough and there is no excessive tension or bend over the table.

Keep away from flammable or explosive materials.

3.3 Risks

Risk exists even when using the machine according to the manual.

WATCH OUT! Heated glue may reach the temperatures of 200°C. Do not touch any hot parts.

The glue may contain harmful chemicals. Therefore, ensure sufficient ventilation of your workplace.

3.4 Important notice

Make sure the machine has been off for at least 60 minutes before storing it in the portable case. That way, the glue in the container will cool down to 60°C. Use a piece of cloth to wipe any adhesive residues on the machine.

Operating instructions EN

The Edgebander is designed for interior work. Do NOT use the machine outdoors!
If you want to prevent debris falling into the glue pot. Put on the lid. If debris is already in the pot, remove

the glue, turn on the machine for approximately 3 minutes, the glue should come out easily now. Re-fill with glue again.

4. SPECIFICATIONS OF THE MACHINE

4.1 Machine description

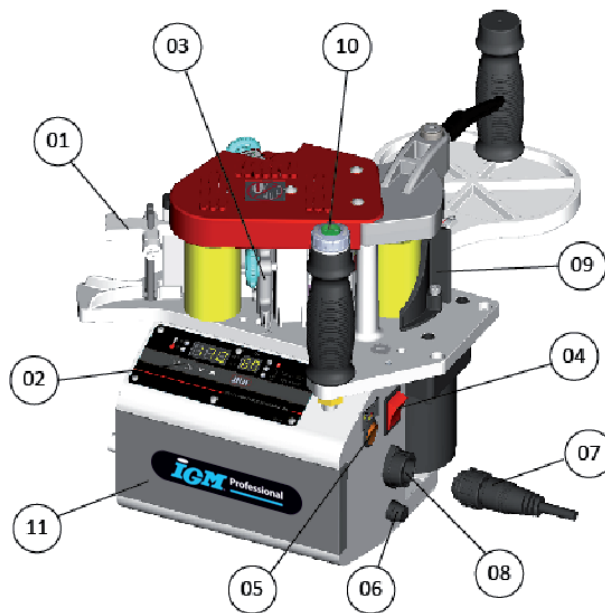
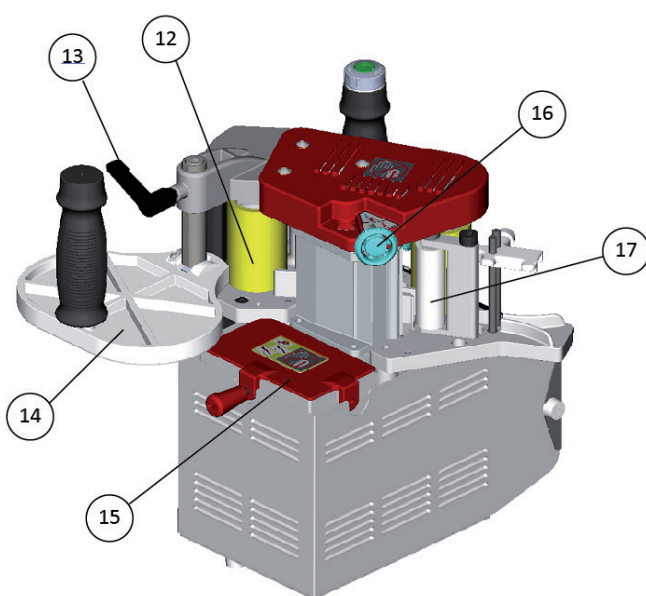

1	Infeed tape guide	10	Speed regulation and off switch
2	Digital display - function settings	11	Battery cover
3	Set up of pressure of tape on application roller the	12	Outfeed roller
4	Main switch	13	Support table locking lever
5	Heating ON/OFF switch for operation battery	14	Support table with a handle
6	Fuse	15	Glue pot cover
7	Power cable plug	16	Regulation of amount of glue
8	Socket for power cord	17	Infeed roller pressure plate
9	Corner guide for simple glueing of inner corners		

4.2 Technical data

Input power	855W / 230V
Tape thickness	0,4 - 3mm
Tape thickness	10 - 65mm
Temperature range	125° - 200°C
Feed speed	2 - 6m/min
Shipping size	34x30x35cm
Weight	9,8kg
Shipping weight	12kg
Warm-up time (120 °C)	4min
Fuse	F 6A (230V)
Cable length	5m
Glue pot capacity	400ml

4.3 Contents

- DR500 Edgebander
- Support table with a handle
- Battery LB24
- Power cord
- Mobile tape holder
- Plastic case with castors
- Sample tape from calibration procedures

5. TRANSPORT, UNPACKING AND ASSEMBLY

5.1 Transport and unpacking

The machine is not assembled due to transport. Assemble before operating. Remove the edgebander from the packaging and place on a flat surface. Check for any apparent transport damages, these could damage the machine or your health.

5.2 Assembly

5.2.1 Connecting the battery for portable operations

- Use the 142-LB24 lithium battery.
- Assembly and connection of the battery**
- Turn off the main switch before connecting or removing the battery.
- Unscrew the screw on the side of the cover.
- Open the battery cover and insert the battery connector into the motor. (pic. 1)
- The battery will only charge when the edgebander is turned on and connected to power supply. The charge status is shown on the control panel.
- Lithium battery: (ICR18650/3,7V x 8) 2200mAh fully charged in 1 hour

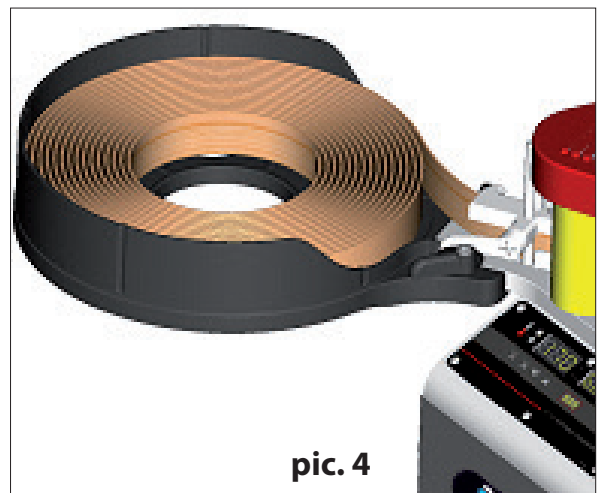
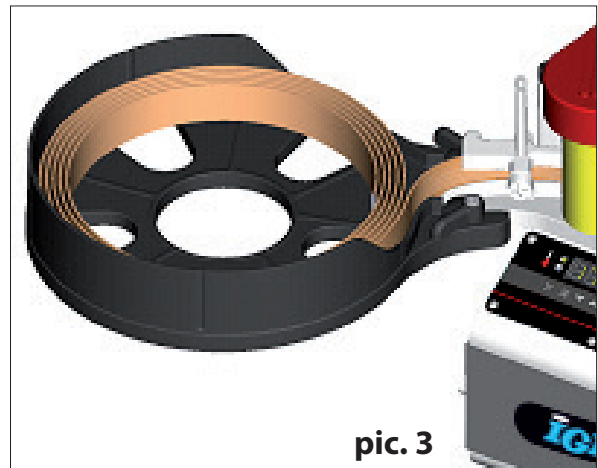

5.2.2. Mounting the mobile tape holder

- Mount the holder from the bottom onto the mouth and flip the levers according to picture 2.
- Place the ball of tape with regard to the winding of the tape. If the tape is wined front side out, load it according to picture 3. If the tape is wined front side in, load it according to picture 4.
- The maximum tape dimensions for the tape holder: width 65 mm x thickness 3 mm x length 12 m.

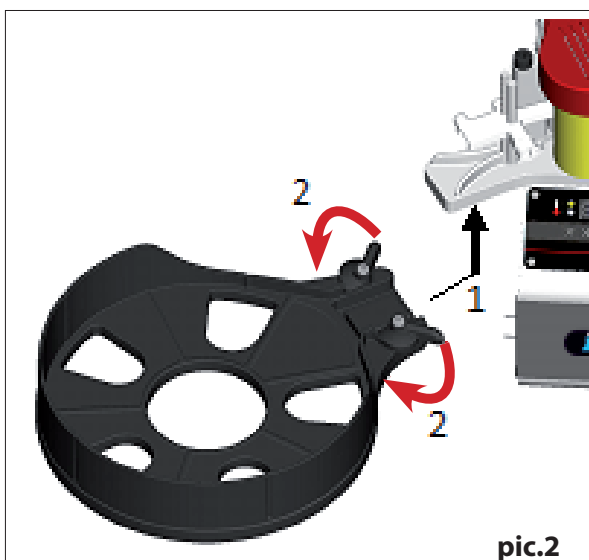

5.2.3 Mounting the corner guide

- Equip the corner guide only when banding inner corners or a radius smaller than 50 mm. It would be getting in your way during other operations.
- Place the corner guide on your edgebander according to pic.5 and tighten the screw.

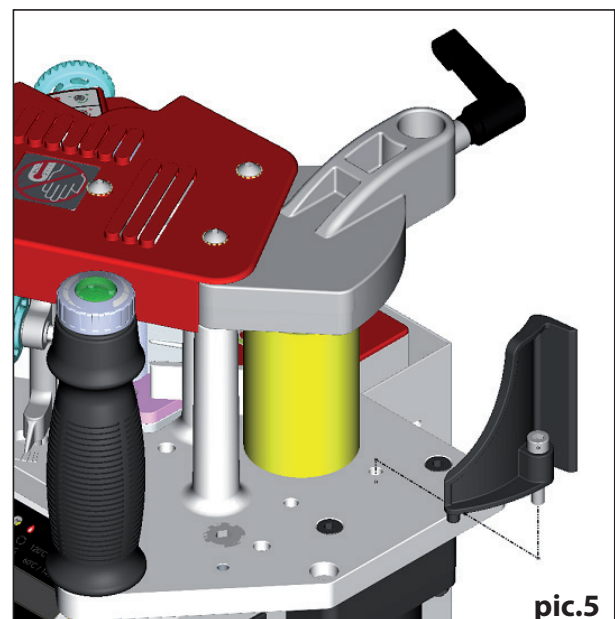

Operating instructions EN

6. SET-UP AND ADJUSTMENT

6.1 Preparing for work

6.1.1 How to measure and set up tape width

- Loosen the screw on the tape stop (pic.6)
- Place the tape under the stop and measure the height (pic.7), tighten the screw.
- Measure the thickness of the banded piece and set up the support table accordingly, make sure to tighten the locking lever properly (pic. 8)

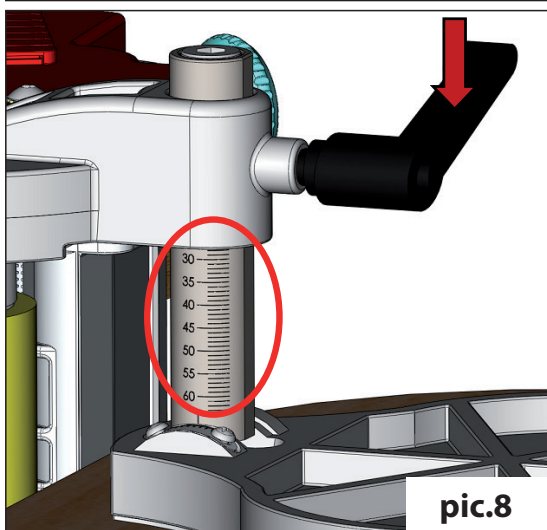
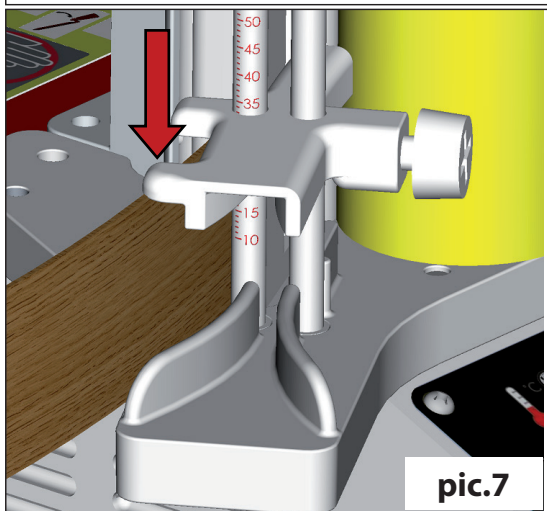
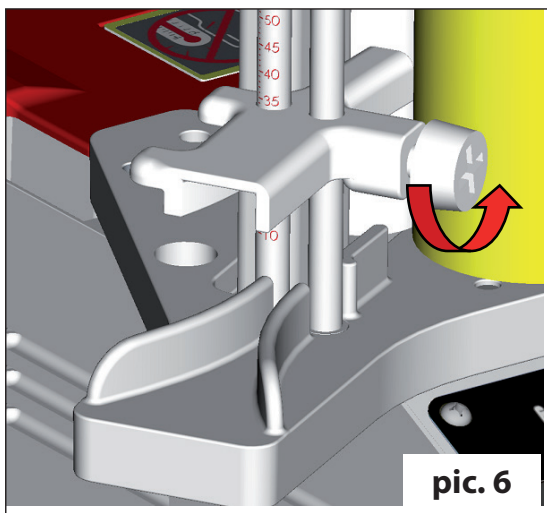

6.1.2 Control and gauge set up of the support table

The pre-set support table is perpendicular to the pressure plate. Place the support table on a mitre gauge (pic.2, gauge not supplied) to check proper alignment. If the table is not perpendicular, loosen the screw (1). Align the table according to the mitre gauge, tighten screw (1). Release screw (3) and set up the gauge (4) to „0“, then tighten again.

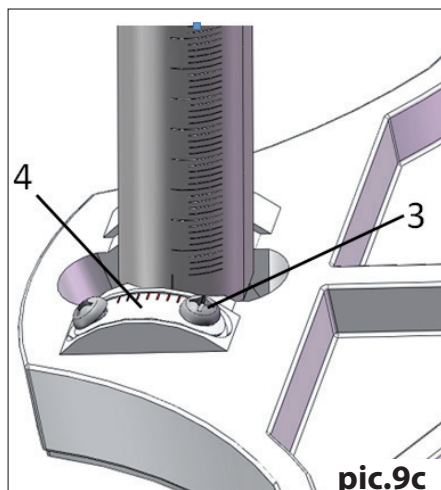
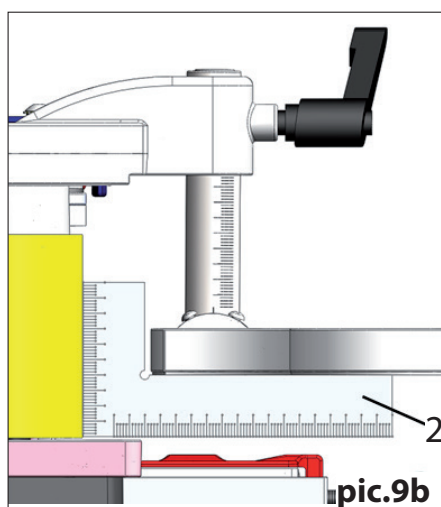
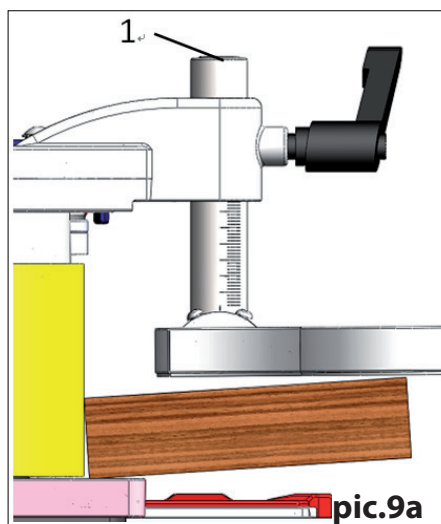

6.1.3 Adjusting the amount of applied glue

The amount of glue is pre-set and should suit the majority of operations.

- If the amount of glue is not convenient. Prepare a test tape, warp up your machine and load the tape. Use the amount of glue adjustment knob to set the demanded quantity. Turning left adds and turning right decreases the amount of applied glue (pic.6) The scale displays the amount of glue.

- **Caution: Do not turn the adjustment knob until the glue has reached operating temperature.**

- Too much glue overflows on the visible side of the tape. Not enough glue is not evenly applied along the whole width of the tape.

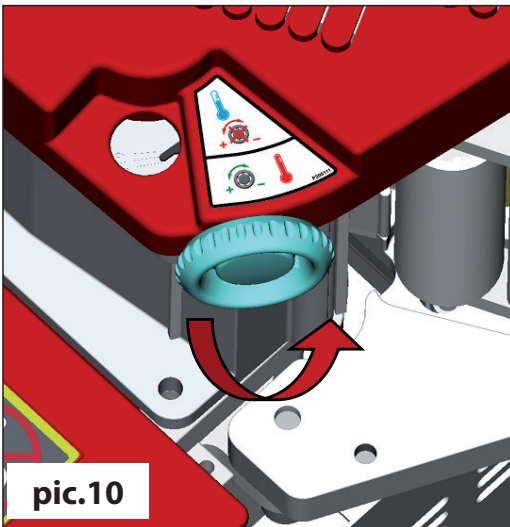

pic.10

6.1.4 Thickness of tape

Set up thickness only when you have a softer or thinner tape than 1 mm. Otherwise, the pressure automatically adjusts to the tape. The thickness can be simply set by a turn of the knob (pic.11).

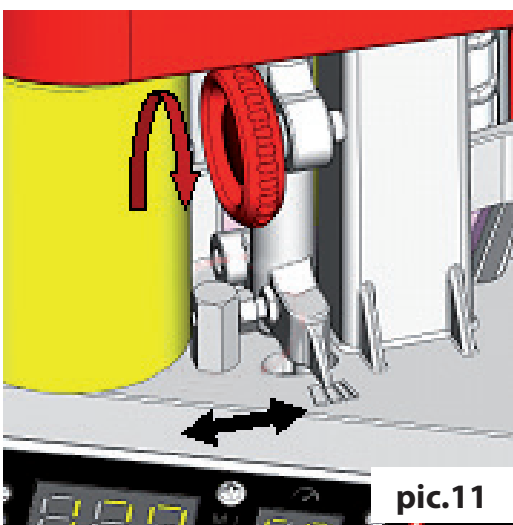

pic.11

6.1.5 Setting up tape length

- Measure the length of the banded edge and leave a bit more of the tape for final trimming.
- Apply enough pressure when trimming the edge, this will improve the finish.

6.1.6 Proper fastening before edgebanding

Fasten the workpiece to a worktop using clamps. Make sure the edge of the workpiece you will edgeband extends beyond the edge of your worktop. It may be more comfortable to use a vacuum suction cup. You can order one from IGM as an optional accessory. Use of the vacuum cup (pic.12)



pic.12

6.1.7 Refilling the adhesive

- Regularly check the amount of glue in the glue pot. We recommend to refill the glue when there is only half of the pot left.
- Loosen the screw on the cover so that it can be lifted.
DO NOT TOUCH THE COVER - it's hot.



pic.13







6.2 Advice for proper operation

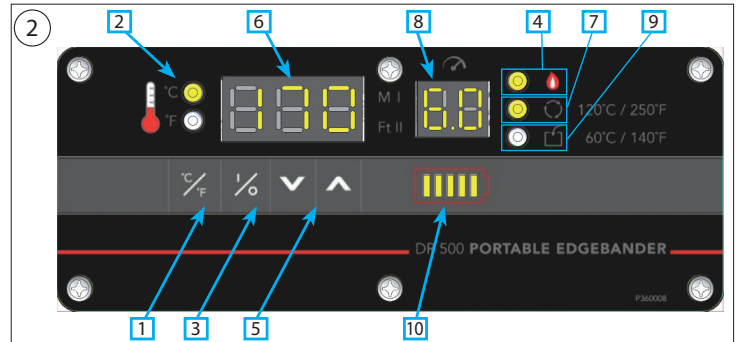
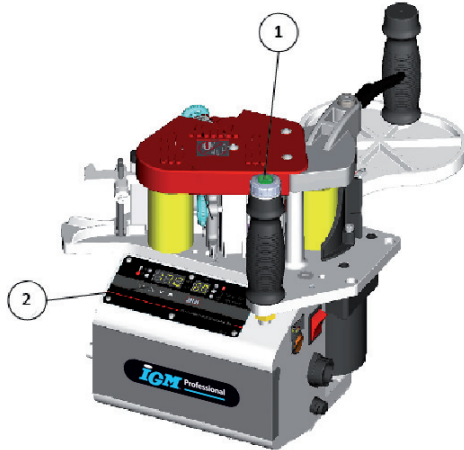

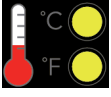

- Keep the machine clean throughout the whole operation.
- Store the workpiece and the tape at room temperature.
- Cold tape or workpiece can affect the quality of adhesion.
- Always maintain enough pressure on the tape when working. Insufficient pressure may result in a weak connection between the tape and the workpiece.
- Store your glue in a cool and dry place.
- A pot full of glue is enough for approximately (depending on the type of glue) 50 m of tape (width 25 mm) or 25 m of tape (width 65 mm).
- Make sure the glue has completely melted before working.
- Use glue supplied by IGM which has an operating temperature of 120-150 °C.
- The edgebander may be used without the power cord only when running on the LB24 lithium battery.

- Use the lowest feed speed when turning on the machine for the first time. Adjust the speed according to your experience and complexity of the workpiece.

6.3 Control panel features

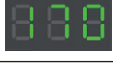

	<p>Feed speed control: the button turns the feed on and off. Turning the ring changes feed speed from 2-6 m/min (clockwise rotation increases speed).</p>
	<p>How to switch between °C a °F</p>
	<p>When the light is on, the temperature is in °C and feed speed in m/min. When the light is on, the temperature is in °F and the feed speed is in Ft./min.</p>
	<p>Heating switch; After turning on the main power switch, turn on the heating switch to begin heating the glue.</p>
	<p>The glue is being heated when the light is on.</p>
	<p>Temperature setup; The temperature changes by one degree after pressing the button once Quick set-up: by holding the button for 3 seconds, you will hear a beep and the temperature set-up will rise quickly.</p>

	<p>The display shows the current temperature in the glue pot</p>
	<p>Operating indicator light: lights up when the temperature is over 120 °C (250 F), you can speed up the heating by turning on the tape feeder.</p>
	<p>Speed indicator</p>
	<p>Safe storage light: When you turn off the heating, this light will light up. And will go out when the temperature in the glue pot goes below 60 °C (140 F). Now you can safely store your machine in the carry bag.</p>
	<p>Battery operation: An indicator will blink after turning off the heating; the indicator will turn off when the temperature in the hot pot falls below 60 °C (140 F). Now you can safely store your machine in the carry bag.</p>

7. OPERATING THE MACHINE

7.1 Edgebanding

Check for debris or dust in the glue pot, turn on the main switch and trigger the heating next to the display. The button on the handle (2) will light up when the temperature reaches 120°C, press the button (1) to accelerate the melting process. Make sure the glue is properly stirred up before working. Turn the feed off and place the tape on the infeed roller. Place the support table on the workpiece and hold the machine firmly with both hands (2), (3). Place the pressure roller approximately 5 cm from the workpiece.

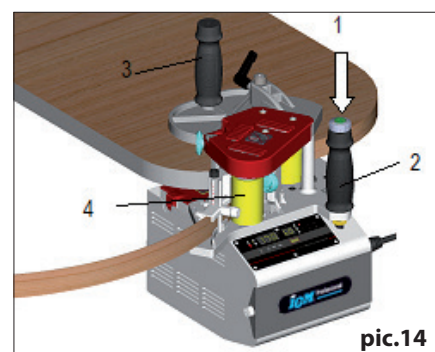

pic.14

Turn the feed on (1), and wait for the tape to reach the pressure roller. Press the tape to the workpiece using the pressure roller. Then allow the machine to run at its feed speed and only check the proper feed of the tape.

7.2 Operation

- After reaching the pre-set temperature and the glue has fully melted, you can disconnect the edgebander from the power supply and run the device using the battery.
- If the temperature falls by 10°C (50 F) when running on battery, the temperature indicator will blink the edgebander will „beep“, to signalize the temperature of the glue is not optimum for your operation. If the temperature falls below 120°C, the motor won't turn on. The edgebander must be connected to the power supply in order for the glue to heat up to the pre-set temperature.
- You have two options when running on battery power: **Heating turned on-** this will run down the battery quickly but will keep the pre-set temperature of the glue. **Heating turned off-** the glue slowly cools down, the battery only



pic.15

runs the feed, the battery will last significantly longer in this mode. Switch the heating on and off using the round switch (pic.16). The feed will run on battery when the edgebander is unplugged. You have approximately 5 minutes before the glue cools down to an unworkable

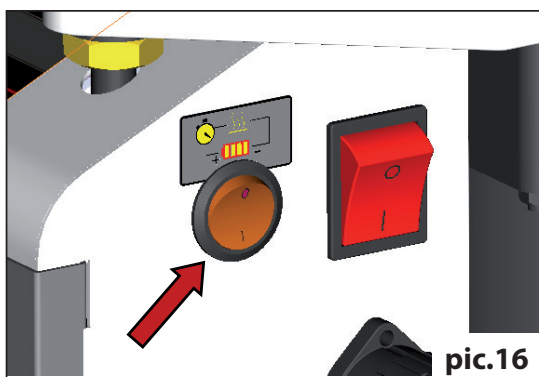

pic.16

7.2.1 Operation in battery mode

When banding large and complicated workpieces, set the edgebander to the highest possible temperature of the adhesive. Then unplug the power cord from the edgebander. Now you can band large and complicated pieces. The cord won't be in your way and you can easily reach all around the banded workpiece. When banding large and complicated pieces using the

battery and the temperature drops by 10°C from the pre-set temperature, turn on the heating of the glue. When you finish your banding, make sure to connect it to the power supply to heat up the glue again and charge the battery.

7.3 Stationary use

It's better to use the machine with a worktable when banding smaller pieces, the worktable is available at IGMtools.com as an optional accessory. That way, you can band edges like on a stationary edgebander.

8. MAINTENANCE AND CONTROL

8.1 Maintenance after work

Clean the machine properly **after every operation** and get rid of any glue on the edgebander with a proper tool or a dissolvent to prevent glue build-up. We recommend having the machine checked after 500 hours of work or **every 6 months of use**. During regular weekly maintenance, you should lubricate the timing chain and the pressure plate with silicone oil. Loosen screws, see (pic.17), and remove the plastic cover. Now you can lubricate the chain and the plate. After maintenance, place the cover back and tighten the screws.

Make sure to clean the hot pot regularly. temperature.

Band the required surface and connect the edgebander to the power supply.

every two months or every 50 hours of operation

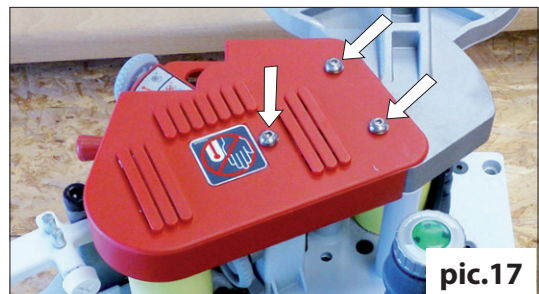

pic.17

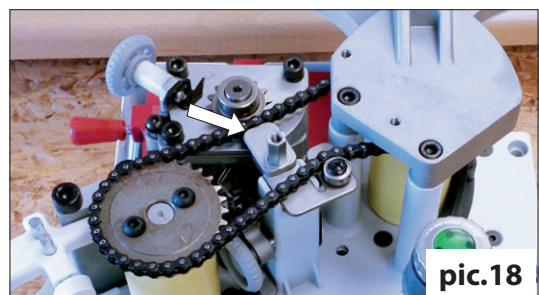

pic.18

of the edgebander. Remove the rest of the glue and refill with a new one.

The machine has to be turned off and disconnected from the power source during maintenance.

8.2 Preemptive control

Regularly check the glue status in the glue pot. Refill the glue when the glue pot is half empty. The heater should be always submerged in the glue.

Operating instructions EN

9. MALFUNCTION ASSISTANCE

9.1 DR500 error messages

The DR500 Edgebander is designed to detect malfunctions and to picture them on its display.

ER1 - Voltage error: the voltage is not optimal for the proper function of the machine.

ER2 - Engine error: please contact an authorized service to check on the function of the motor.

ER3 - Heating error: should the temperature exceed 220°C, contact the authorized service centre to check on the heating function.

ER4 - Internal error: please contact an authorized electrical service centre.

9.2 Solution to problems

Malfunction	Cause	Repair
Cannot turn on the machine	Damaged fuse	Replace the fuse (use a fuse with the same value)
The tape is not completely covered with the glue	The glue is not properly melted	Open the glue pot and check if the glue has dissolved properly.
	The amount of glue in relation to the width of the tape is improperly set	Increase the amount of glue with the control knob. (see chapter 6.1.3)
	Deformed tape	Use a tape of better quality.
	The glue was applied poorly to the banding roller	Turn on the feed and let the glue circle between the applicator and the glue pot
The tape doesn't hold on the workpiece	The pressure roller isn't perpendicular to the edge of the workpiece	Adjust the angle of the support table so that it's perpendicular to the edge (see chapter 6.1.2)
	Overheating can degrade the properties of the glue	Replace the old glue in the pot with the new one
	The glue hasn't been heated to the right temperature	Check the label on the glue and set the temperature accordingly
The tape has twisted while banding	The feed speed is slower than the feed of the tape	Increase pressure on the workpiece, adjust feed rate
The tape is slipping on the infeed roller	Dust or debris on the infeed roller	Clean the infeed roller
The feed won't turn on	The glue isn't melted enough, the operating temperature hasn't been reached so far	The motor can be turned on after reaching 12 °C to ensure proper temperature for work.
Overheating	Malfunctioning temperature control	Let a qualified electrician replace the temperature detector

10. PROTECTION OF THE ENVIRONMENT

Protect the environment.

Your machine contains materials that can be recycled. Please, let specialized institutions handle the machine.

11. ACCESSORIES (spare parts)

iGM Tape Holder for Edgebander DR500-BR300

142-BC25

IGM Battery Set for Edgebander DR500

142-LB24

IGM PD80 Edgeband Trimmer

142-PD80

IGM End Trimmer for Shaped and Straight Panels

M951

IGM Fachmann Edge Banding Hand Trimmer **M950-00001**

IGM Worktable for Edgebander and Trimmer for DR500-BR300

142-ST95B

IGM Straightline Edgebanding and Trimming Kit for Worktable ST95A

142-ST97

Glue Technomelt KS224 for IGM Manual Edgebanders - 5kg pack

M967-5

Glue Technomelt KS224 for IGM Manual Edgebanders - 25kg pack

M967-25

IGM Vacuum Clamp One-sided, set

M964

IGM Lever Valve for Vacuum Clamp M964

M966-01

IGM Plastic T-splitter for Vacuum Clamp M964 **M966-0**

